

SOFT SKILLS AND GRADUATES'EMPLOYABILITY IN THE 21ST CENTURY FROM EMPLOYERS' PERSPECTIVES: A REVIEW OF LITERATURE

Al Asefer, M.¹ & Zainal Abidin, N. S.¹
¹*Infrastructure University Kuala Lumpur, Malaysia*

ABSTRACT

Enhancing one's employability or upgrading one's skills is a significant purpose of Human Resource Development. Personal circumstances, individual variables, and environmental influences all play a role in the employability construct. The purpose of this paper is to investigate soft skills and employability from employers' perspectives. Organizations consider human capital critical to their success and usually make efforts to hire the best possible individuals. They usually prefer recruiting employees who possess a fine-quality combination soft skill; highly required by employers. Employers nowadays are seeking graduates who have both academic qualifications and are highly skilled. It is also important to mention that employers are placing a high value on soft skills. Thus, there is an increasing need for a better understanding of the importance of graduates' soft skills required with the increasing demands from employers. Higher education institutions must understand what employers want from their graduates. Hence, employers' perspective towards soft skills is important. Soft skills must be acquired and developed during students' life for them to do effectively in both their academic and have qualities that improve future employability. This paper is based on information collected from different published papers, internet sources and newspapers, it represents a review of the literature in an attempt to answer several questions about the relationship between soft skills and employability in the 21st century. It concludes that soft skills is a strong predictor to enhance employability among graduates in today's dynamic demanding global work environment.

Keywords:

Employability, Soft skills, Employment skills, Employment, Graduate employment, Employers

INTRODUCTION

The job market today is a dynamic and challenging sphere for young people graduating from various educational institutions; the job opportunities are more for graduates who possess employability skills that are expected at workplaces. But only about 30% of the candidates who appear for interviews get selected (Nisha & Rajasekaran, 2018) and one of the main reasons is due to lack of proficiency in English and the employable skills necessary for professionals today. Hence, higher education institutions need to equip graduating students with the skills essential for the workplace; as it has become an urgent concern (Cimatti, 2016). In this context, several nations throughout the world have expanded their focus on skill development, as to prepare graduates for the world of employability as required by employers (Abelha, Fernandes, Mesquita, Seabra & Oliveira, 2020).

Many researchers have defined employability from several perspectives and on what it means to all who are concerned with this term: employers, higher education institutions and graduates themselves (Natalia et al., 2015; Osmani et al., 2015; Sung et al., 2013). The term employability is a multidimensional concept and is used in contexts of transferable, generic, intellectual, interpersonal, industry-specific, and cognitive skills. Despite the lack of a commonly recognized definition, broadly defined, employability refers to a specific set of skills and personal attributes that will assist an individual in securing a job, retaining employment whilst staying relevant within the labour market (Romgens, 2019). Soft skills are career attributes, which are difficult to both master and measure, such as the capacity to communicate, solve problems, teamwork skills, leadership skills, time

management skills, etc. Today soft skills are popularly referred to as employability skill (Patacsil & Tablatin, 2017).

Employers deem soft skills as employability skills owing to the fact they are needed to have a harmonious relationship with co-workers and customers. An employee's job performance and career success are contingent on the effective utilization of soft skills (Nusrat & Naz 2016). Truong and Laura (2015) opined that the development of soft skill as an academic discipline is still under development, and that's why different researchers defined it differently. Advocates such as Truong and Laura (2015) defined personal skills such as the capacity to communicate, and problem-solve, and possess leadership qualities, motivation and the ability to work well in a team. No one factor alone can determine the employability of a person. It's a consequence of a number of factors acting together but according to several researchers such as Fogleman (2019) soft skills like teamwork, communication, leadership and critical thinking are widely required by employers, and when companies hire new personnel, these "skills" should rank as high as technical skills. The objectives of the paper are to examine the soft skills and employability of an individual, to look into various studies related to soft skills and employability and to explore how soft skills could be a strong determinant to the employability among our potential graduates from employers' perspective.

PROBLEM STATEMENT

Despite the increasing demand of the labour market, employers still seem to have difficulty in filling several vacancies because of the claim that majority of higher education (HE) graduates are not employable and lack skills (Okolie and Asfa, 2017). In certain cases, some companies are even emphasizing more on soft skills instead of hard skills (Ramlan & Ngah, 2015). University students have been lacking certain skills such as soft skills especially problem solving and communication skills, difficulty in applying knowledge, and lack of English communication skills (Azmi, Hashim & Yosuff, 2018). Employers deem soft skills as employability skills while blaming higher education for not equipping graduates with the skills needed, and continuously highlighting students' lack of soft skills (Hurrell, 2016) which are needed for today's rapidly changing work environment. The research questions that guided this study focused on soft skills and employability from employers' perspectives in order to explore importance of soft skills to employability enhancement.

Research objectives in this study are to: (i) investigate soft skills and employability from employers' perspectives (ii) determine the relationship between soft skills and employability in the 21st century and (iii) explore how soft skills can be a major predictor of employability.

Research questions in this study are : (i) What are soft skills and employability from employers' perspectives? (ii) What is the relationship between soft skills and employability in the 21st century? (iii) Will soft skills be considered a major predictor of employability?

LITERATURE REVIEW

This review paper focuses on "employability" and its associations to "soft skills" from related past studies and the extent of employability and soft skills from employers' perspective.

Employability

Many different definitions of graduate employability exist (Williams et al., 2015) and one commonly used to describe employability is a set of achievements, skills, understandings and personal attributes

that makes graduates more likely to gain employment and be successful in their chosen occupations (Romgens et al., 2019). The earlier definition of employability emphasized the ability of graduates to obtain a job which used the simple measure of testing whether a graduate had obtained a job within six months of leaving university (Asiri et al., 2017). The Canadian Labour Force Development Board (CLFDB) revealed that employability is “the ability of individuals to gain valuable employment in the interaction with the labour market”. Paying more attention to employability at work which is aligned with the International Labour Organization (ILO) termed employability as “the ability to make progress at work and to react to changes in work (Li & Sun, 2019)

The notion of employability has gotten a lot of attention in the literature, but it still needs more research (Hooley et al., 2017). Despite variations in definitions of ‘employability’ common ground can be found as mentioned earlier by Wharton et al., (2014). The term ‘employability’ refers to the competences and abilities that graduates must have in order to improve their employment chances in the labour market as well as the country's economic and social growth (Jeswani, 2016; Phago & Thwala, 2015). Sutil & Otamendi (2021) reemphasized and pointed that employability is the capability to move self-sufficiently within the labour market to realise potential through sustainable employment. For the individuals, employability depends on the knowledge, skills and attitudes they possess, the way they use those assets and present them to employers and the context for example personal circumstances and labour market environment within which they seek work. Rothwell & Rothwell (2017) highlighted that employability has the capacity to move oneself to an adequate degree with the labour market to realise potential through prospective employment which depends on the knowledge, skills and attitudes. Behle (2020) termed employability as the ability to find, keep and progress in graduate employment. This was confirmed by Koanelakis & Petrakaki (2020) who believed that employability is a collection of accomplishments – skills, understandings, and personal characteristics – that makes graduates more likely to obtain employment and succeed in their chosen vocations, benefiting themselves, the workforce, the community, and the economy.

However, Hlavackova et al. (2016) found that the employability of an individual is the capacity to adapt to professional demands and current dynamics of new labour markets, and it is directly related to the ability to find and maintain employment. While Hooley (2017) advocated that employability is a multifaceted concept that has both internal and external facets. Apart from its multifaceted employability, the latter encompasses academic performance, career management skills and labour market awareness. Coetzee & Schreuder (2017) measured employability in terms of a person's ability and willingness to become and stay desirable in the labour market, as well as their aptitude to succeed in a variety of occupations; Coetzee added that graduates' ability to find, create, and maintain satisfying work, as well as having the information, understanding, abilities, experience, and personal characteristics to move self-sufficiently within the labour market. Realising one's potential through long-term, rewarding working experience and having skills or knowledge that permit a person more likely to secure a job in which they can be satisfied and successful (Coetzee & Schreuder, 2017).

Recently, findings revealed that graduate employability include graduates' capacity to find work in the labour market, as well as their ability to engage in and contribute to the knowledge economy by using what they learned in higher education, while also improving their social status and the economy of their nation (Majid et al., 2020). More importantly, Balangen et al. (2021) found that employability not only involved one's capacity to find and retain a satisfying job but also employability in a broader sense is the ability to move independently within the labour market in order to realise one's potential through sustainable employment. The extent to which employers' perspectives related to soft skills are discussed is as follows:

Soft Skills

Over the last decades, research has largely focused on the hard skills and recognize how they are required by the labour market (Balcar, 2016);only limited attention has been devoted to the investigation of soft skills (Ciappei & Cinque, 2014). It has been argued that, in order to achieve a positional advantage, graduates need to develop and acquire a combination of hard skills and soft skills (Clarke, 2017). Many organizations recognize the fact that the technical skills of their employees are not enough to achieve the organization’s goals, this is why employers of many industries consider soft skills critical for business success (Stewart et al., 2016).

The function of a higher learning institution is not only to train a selected elite group of school leavers, but to offer a focused educational experience this includes providing students the required knowledge and skills to pursue their respective careers (Ramalu et al., 2013) however, many academics and researchers agree that there is an increasing gap between soft skills expected by employers and the level of soft skills possessed by graduates (Singh & Jaykumar, 2019). Soft skills are difficult to measure and evaluate comparing to hard skills (Abujbara & Worley, 2018) but employers usually prefer to recruit an individual who possesses soft skills in addition to hard skills (Maclachlan, 2019). Later, Majid, Eapen & Aung (2019) pointed that there was evidence that soft skills compete with hard skills in their ability to predict employability. Alongside, Charlton (2019) argued that strengthening soft skills is one of the best investments a graduate can make for a future career. Soft skills necessary at the workplace are communication, problem solving, teamwork, decision making, leadership, critical thinking, time management & creativity (Lavender, 2019). Tracing from several institutions, notably the European Union (EU) and the Organization for Economic Co-operation and Development (OECD) had proposed several titles for Soft Skills through history as shown in Table 1 below. Specific Competences refers to hard skills, whereas Generic Competences refers to soft skills.

Table 1: Different names proposed to define soft skills.

Names proposed to define soft skills	Proposed by
Life skills	World Health Organization WHO (1993)
Transversal skills	Istituto per la formazione e l’orientamento al lavoro ISFOL (1998)
Generic Competences	Tuning project (2000)
Key competencies for a successful life and a well-functioning society	Organization for Economic Co-operation and Development OECD (2003)
Key competences for lifelong learning	European Union EU (2006)
21 st century skills	Ananiadou & Claro (2009)
Transferable skills	RPIC- ViP (2011)
Future work skills	Institute for the Future IFTF (2010)
Soft Skills for talent	Manpower Group (2014)
Skills for social progress	Organization for Economic Co-operation and Development OECD (2015)

Source: Cinque (2015)

Soft skills are personal attributes that enhance an individual's interactions, job performance and hard skills that tend to be specific to a certain type of task or activity. It also refers to social gracefulness, and fluency in languages, personal habits, friendliness and optimism that mark to varying degrees. Soft skills complement hard skills, which are the technical requirements of a profession. It can also be an important part of the organization especially if the organization is dealing with people face to face (Pachauri & Yadav, 2014).Similarly, soft skills help people to adapt and

behave positively so that they can deal with the challenges of their everyday life. In this instance, soft skills relate to a considerable range of interpersonal and social qualities and competences, transferable across economic sectors and industries (Hurrell, 2016; Deloitte Access Economics, 2017).

Soft skills development among students is essential for finding a job. Employers mostly look for few specific soft skills during hiring new employees which include creativity, leadership, critical thinking, communication, time management, teamwork, problem solving, etc. (Patacsil & Tablatin, 2017). The importance of these soft skills relies on considering them an important part of the employability skills and knowing the definition of each of them will ease the learning process of each skill as mentioned by many scholars as shown in Table 2 below:

Table 2: Soft Employability Skills

Skills	Definition
Communication skill/ foreign language	Understanding and performing in a language different from the mother tongue. It is the skill that helps transmitting information and common understanding from one person to another. Good communication skill requires knowledge and understanding of social and cultural factors in a situation.
Problem solving	Engaging in the action or thoughts necessary to find solution to a difficult of complex question or situation and resolve conceptual problems.
Leadership	The ability to motivate and positively influence others to achieve goals. It is a behaviour, role relationship, influence and interaction patterns. Graduates should develop and lead individual or team activities, addressing challenging situations.
Critical thinking	Gathering, analysing and articulating information from different sources for solving problems and making decisions.
Creativity	Thinking outside the box in order to bring new ideas to solve problems.
Decision making	Thinking of several choices, relevant information and predicting the consequences.
Teamwork	Involves a set of interdependent activities performed by individuals who collaborate toward a common goal.
Time Management	The process of planning and exercising conscious control of the time spent on specific activities to work smarter than harder.

Source: Amirrudin & Salleh (2016)/ Ornellas et al.(2018)/ Shivoro et al. (2017)/ Kashyap (2019)/ Sanyal & Hisam (2018)/ Li et al. (2019)

Employers' Perspective

The increasing problem of graduate unemployment has been linked to the low level of graduate competency and quality of graduates that do not match with employers' expectations (Perera et al., 2017). In addition, employers have continuously provided feedback that the graduates lack English language proficiency, communication skills, analytical skills, and critical thinking (Nadarajah, 2021). The lack of soft skills has a negative impact on company outcomes such as employee behaviour, safety, engagement, and productivity. Companies are competing on the basis of employee expertise, which has increased the value of soft skills (Borghans et al., 2014). Some critics argue that in today's ever-changing economic environment, graduates from higher education institutions are unable to meet employers' expectations and relevant job requirements (Kahiroh et al., 2016; Rohani et al., 2016).

From the perspective of employers, employability often seems to refer to work readiness, that is, possession of the skills, knowledge, attitudes and commercial understanding that will enable fresh graduates to make productive contributions to organizational objectives soon after commencing employment. The employability mismatch was mentioned in Ismail, Chick and Hemdi (2020) where it was revealed that lack of development in the acquisition of “soft skills” contributes to the gap in graduate employability. Employers seek applicants with capabilities and skills appropriate for the work environment (Jeswani, 2016). Consequently, findings suggest the need for future development of current soft skills. The analysis identified “weakness in English language proficiency” as one of the primary factors that led to unemployability. A research brief reported by Hart Research Associates (2013) on behalf of the American Association of colleges and universities indicated that employers want graduates who possess soft skills such as critical thinking, problem solving and communication and according to another survey conducted by the Association of American Colleges and Universities, there is a disconnect between how higher education institutions prepare its scholars to believe in their chosen field and how employers view graduates' preparation. As per the findings of this survey, current university graduates are well prepared in written and oral communication, innovation, complex problem-solving, critical thinking and analytic reasoning, and applying their knowledge and skills to real-world settings, as judged by about a quarter of the employers surveyed. However, more than 60% of graduates believe they are well equipped in these soft skills, according to the findings. This finding emphasises the need for tertiary education to develop new and active techniques for measuring and communicating their graduates' achievements. Employers have stated that they require an understanding of soft skills, and higher education institutions must understand what employers want from their graduates (Kruger, 2015). A study by Messum et al. (2016) examined the required employability skills of new graduates in Australia and findings revealed that soft skills are among the required skills.

Apart from employers who require graduates to have the hard skills necessary for their specific professions (Low et al., 2016); soft skills, on the other hand, have been shown to be more significant in studies since they have received more emphasis in organisations and are in higher demand by employers (Dunbar et al., 2016; Kahirol et al., 2016; Stewart et al., 2016). In the same vein, this was supported by Ali et al. (2017) who reported that employers are placing a high value on graduate soft skills. Conversely, unemployed graduates as mentioned by employers are found to be lacking in various employability soft skills and knowledge such as communication and problem-solving skills (Omar & Rajoo, 2016). Similarly, employers are saying that fresh graduates are unhireable because they lack the requisite skills required for the job (Ejiwale, 2014). This led to the need to investigate deeply the relationship between soft skills and employability.

Soft Skills and Employability

Today, soft skills are some of the most in-demand skills in any workplace. Recently, educational researchers and employers have placed increasing attention on the importance of knowledge or also known as soft skills as evidence suggests that soft skills are an important predictor in employability (Nazron et al., 2017). This was further confirmed by Vanitha & Jaganathan (2019) found that graduates with skills like positive attitude, effective communication, problem solving, time management, team spirit, self-confidence, handling criticism and flexibility which are known as soft skills as a whole have much better chances of survival in the tough corporate world compared to those who are lacking in soft skills and that employability skills are very essential in the current global job market; LinkedIn recently analysed hiring trends across its platform to determine the most sought-after skills. Data suggest that a range of soft skills, including, communication, problem solving, time management and creativity, are the most required among employers (LinkedIn Global Talen Trends, 2019) and highly sought after.

Hart Research Associates (2015) reported that 91 percent of companies believe that a potential employee's critical thinking, communication, and problem-solving talents are more essential than their college major. Advocates such as Matteson et al. (2016) emphasized the importance of soft

skills as an interchangeable skill related to any occupation and sector. Soft skills have been proven to be important in a variety of fields, including management, IT, education, administration, hospitality, medicine, and pharmacy. The importance of instilling soft skills into graduates has grown in recent years as the use of soft skills in the workplace has gotten a lot of attention (Assan & Nalutaaya, 2018). The Canadian Education and Research Institute for Counselling's "National Business Survey" on 500 employers based on the requirement of soft skills at work suggest a number of soft skills based on occupation and profession, concluded that communication skills, teamwork skills and time management are just a few of the many skills that employers consider important for employability (Valdez, 2015).

Among these soft skills include communication, creativity, problem-solving and teamwork. These attributes represent core skills that support an individual's ability to acquire and maintain a job. Communication soft skills serve as a tool to engage in conversations with colleagues and relate expectations and according to studies, "communication should be viewed as a transaction in which participants construct meaning together in a trusting environment (Uzun & Ayik, 2017). Employers desire individuals with strong soft skills to foster a positive working environment and enable them to interact effectively while maintaining control (Matteson et al., 2016). On the other hand, a well-functioning team is a valuable asset to any company. Indeed, a successful team has the capacity to take on more complicated tasks and smooths the process of communication by offering better space for free discussion and collaboration among team members, therefore improving the productivity of not just the team but also the company as a whole (Tripathy, 2018). This was confirmed by Sousa & Rocha (2017) who asserted that the most important soft skills potential employees require to operate successfully at work include leadership and team management skills, and the ability to manage time. Similarly, good and efficient time management is a key skill, a professional skill required to function well in our current jobs and to advance our chances for employment (Forsyth, 2019). Additionally, critical thinking appears to be a crucial soft skill for a variety of organisations. Which is now recognised as a crucial component of employment success (Zuo et al., 2018). Tripathy (2019) asserted that soft skills training has become essential for increasing one's ability to work more effectively, maximise job performance, and advance in one's employment.

In today's increasingly competitive world, mastering soft skills will not only help an employee stand out from the crowd, but will also improve relationships, work performance, and employability development. Recent evidence suggests that soft skills are as productive as professional skills (Balcar et al., 2019). Similarly, Monster (2019) has also researched this topic and goes even further: 85% of recruiters involved in their study has taken in account the importance of soft skills during the process of recruitment and employment. Before hiring new employees, recruiters in general like to see a fine blend of soft skills and competencies among the job candidates in addition to discipline-based knowledge and skills.

Oussi & Klibi (2017) conducted research in Tunisia with a sample of 180 students and the study found a significant relationship between communication skills and employment. Similarly, Vyas (2019) research study clearly indicates that soft skills are vital requirements and in demand by hiring organizations. The latter stated the need to be found within business management students for a better career and that some of the soft skills required by employers are communication skills, leadership skills, analytical thinking skills, teamwork skills and problem solving skills, he also stated that employment opportunities increase when students have soft skills and it increases opportunities to develop a career in a new direction as well as giving the confidence to crack interviews and present themselves in a better way. Nusrat and Sultana (2019) identified desired soft skills frequently asked by recruiters for graduates to sustain employment, study was in Bangladesh using a quantitative approach and found that there is a positive correlation between soft skills and employment.

Gerhardt (2019) conducted a research project in London and used qualitative study on a sample of five group leaders among students, Gerhardt stated that the research serves as an intervention between students' leadership skills and their confidence in employment. His study

hypothesized that leadership skills would positively affect employment among graduates. Also Kelly (2017) conducted research project in Australia using a qualitative method as well and a sample of 100 students in the university and found that leadership is one of the critical skills for students to be employed. On the other hand, Gerhardt (2019) stated that proficiency of soft skills is important towards employability, which he conducted research project in Tanzania using a quantitative approach. The respondents were final year students of bachelor degree and postgraduate students as well and results showed a positive relationship between teamwork skills and employment. However, employers often find soft skills deficiency among the job applicants (Johnson, 2016; Roos et al., 2016). Therefore, soft skills have become one of the needed criteria while hiring employees. Since soft skills help one to get and keep employment as well as successfully influence and lead others at work (Rao, 2018).

METHODOLOGY

This article is based on information collected from different published papers, internet sources and newspapers, it represents a review of the literature in attempt to determine the relationship between soft skills and employability and the importance soft skills from employers' perspective.

The conceptual framework was based on previous studies. Specifically:

- Soft skills are an appropriate approach for enhancing employability (Rahmat et al., 2017; Singh et al., 2017).
- Successful implementation of soft skills leads to improvement of employability (Hamid et al., 2014).

The dependent variable (DV) in this study is employability. The independent variable is soft skills with its dimensions of communication skill, problem solving, leadership, critical thinking, creativity, decision making, teamwork and time management. These soft skills are important in enhancing employability (Vanitha & Jaganathan, 2019; Uzun & Ayik, 2017; Oussi & Klibi, 2017; Kelly, 2017).

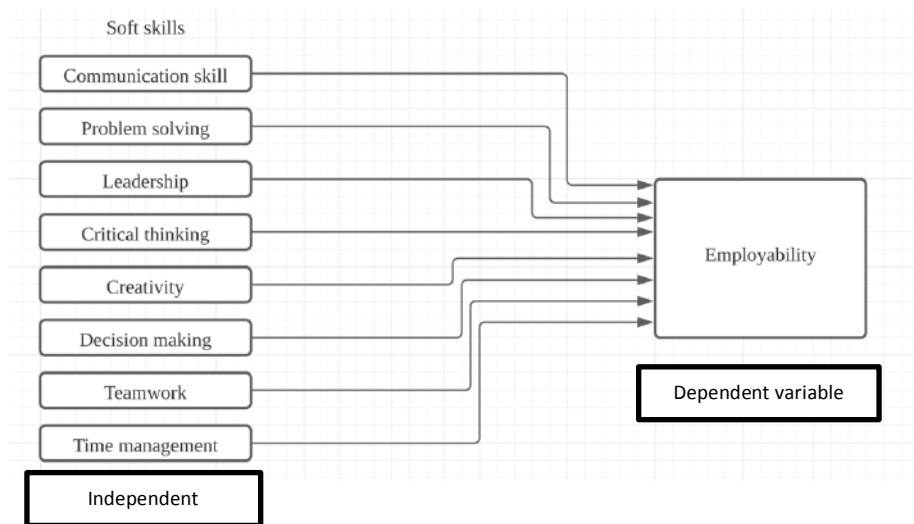

Figure 1: The Conceptual Framework of Soft Skills and Graduates' Employability: Employers' Perspectives

FINDING AND DISCUSSION

Based on the review of the existing literature there is no scientific consensus on the definitions nor concepts of soft skills in pedagogical theory despite its widespread use. Soft skills are regarded as traits (Khanna, 2015), behavioural or interpersonal skills (Nathan, & Rajamanoharane, 2016), non-technical competencies (Stewart et al., 2016), interpersonal qualities (Robles, 2012), non-technical or non-domain skills (Kaushik, & Bansal, 2015), nontechnical traits and behaviours (Klaus et al., 2007), a habit (Khanna, 2015), personal characteristics (Gruzdev et al., 2018) or personal attributes (Robles, 2012; Sousa, & Rocha, 2017), an ability to work in different working environments (Labzina et al., 2019). Hard skills aid in the acquisition of employment, whereas soft skills aid in the retention of employment. As a result, it is critical to combine hard and soft skills in order to advance quickly in one's profession.

Employers require graduates to have the hard skills necessary for their specific professions (Low et al., 2016). However, beyond that, soft skills which have been known as the 21st century skills are largely centred on "deeper learning" skills such as critical thinking, problem solving and teamwork are made of a combination of soft skills and studies have found that those soft skills are more important because it has been receiving greater attention in organisations and are in higher demand by employers (Dunbar et al., 2016; Kahirol et al., 2016; Stewart et al., 2016) and as was mentioned by Cimatti (2016) it can be presumed that the assessment of soft skills during the academic years is challenging. However, more importantly, students need to develop their soft skills before entering the work environment. On the other hand, since its inception in 2011, much has been stated in the fourth industrial revolution (IR 4.0). Among skills that have been labelled in IR 4.0 include skills and competencies such as soft skills, communication, creativity, and problem solving, which are commonly referred to as 21st-century skills (Chaka, 2020), also among the vital skills for IR4.0 necessary for employability. In turn, the availability of necessary skills and competences in a country's workforce will have a considerable impact on the micro-and macro-level adoption of Industry 4.0. Furthermore, the workforce's skills and qualifications will play a significant role in fostering organisational innovation and competitiveness (Benesova & Tupa, 2017; Mavrikios, Georgoulas & Chrissolouris, 2018). Lacking the necessary skill set, on the other hand, will result in a notable reduction in performance and reduced competitiveness in organisations. However, according to Schallock, Rybski, Jochem, and Kohl (2018). Apart from IR 4.0 focusing more about technology growth; it cannot be denied that soft skills requires a focus on human resource development, which includes the development of future-oriented skills. Unemployment is one of the most pressing issues in developing nations, with causes such as a mismatch between available skills and industry requirements; a high proportion of unskilled labour, and insufficient education all contributing to high unemployment (Nazron et al., 2017). Soft skills have been in higher demand by employers. Thus, soft skills are an important predictor for employability in today's competitive labour market (Nazron et al., 2017).

CONCLUSION

This paper aims to establish a significant contribution of various aspects of soft skills in employability by looking at various literature in the relevant area and it seems that soft skills to be a major predictor of employability in most situations as pointed out by Naim (2017) that communication skill, critical thinking and problem-solving ability are crucial to develop for an employee to become skilled professional and employable. Hard skills help with finding employment, whereas soft skills help people keep their jobs. As a result, in order to grow rapidly in one's work, it is necessary to combine hard and soft skills.

Soft skills training, according to experts, should begin while a person is a student in order for them to do well in both their academic and future job environments (Penratanahiran & Thongkam, 2021). This study could assist the higher education and students themselves in preparing students with soft skills to meet the requirements of the employers. A major scope the paper put forwards is the need for empirical proof for the importance of soft skills to employability from students' perspective as it is important to investigate the reasons behind students and graduates lacking soft skills required by the employers in the current labour market.

ACKNOWLEDGEMENT

This research was carried out in the Discipline of Business, Information and Human Sciences, Infrastructure University Kuala Lumpur. The authors would like to deeply thank IUKL for giving us the opportunity to publish this research at *IJIRM*.

AUTHORS BIOGRAPHY

Al Asefer Marwa Mohammed is a PhD candidate at IUKL in the faculty of Business, Information & Human Sciences. Experienced in employees engagement & management. Experience as an HR advisor, held managerial positions such as Assistant Manager & Customer Service in Malaysia. Email: marwa22288@yahoo.com

Noor Saadah Zainal Abidin, PhD is a professor in the Faculty of Business, Information and Human Sciences, IUKL. Held administrative positions such as Dean for Business Faculty and Centre of Postgraduate studies in IUKL, Acting Dean, Head of post graduate program, and a member of the Malaysian Institute of Management. Email: saadah@iukl.edu.my

REFERENCES

- Abujbara, N. K., & Worley, J. A. (2018). Leading Toward New Horizons with Soft Skills. 26(3), 247-259. <https://doi.org/10.1108/OTH-10-2017-0085>
- Abelha, M., Fernandes, S., Mesquita, D., Seabra, F., & Ferreira-Oliveira, A. T. (2020). Graduate Employability and Competence Development in Higher Education—A Systematic Literature Review Using PRISMA. *Sustainability Journal*, 12(15). <http://doi.org/10.3390/su12155900/>
- Amirrudin, S., & Salleh, N. (2016). Refusal Strategies in English among Malay ESL Students. *Infrastructure University Kuala Lumpur Research Journal*, 4(1). <https://iukl.edu.my/rmc/wp-content/uploads/sites/4/2018/04/4.-Refusal-Strategies-in-English-Among-Malay-ESL-Students.pdf>
- Artess, J., Hooley, T., & Mellors-Bourne, R. (2017). Employability: A Review of the Literature 2012-2016. Higher Education Academy (HEA). <http://hdl.handle.net/10545/621285>
- Asiri, A., Greasley, A., & Bocij, P. (2017, July 9). A Review of the Use of Business Simulation to Enhance Students' Employability (wip). Society for Computer Simulation International, San Diego, CA, USA, Article 39, 1-6. <https://doi.org/10.5555/3140065.3140104>
- Assan, J. K., & Nalutaaya, V. H. (2018). Africa's Youth Unemployment Challenge and The Pursuit of Soft Skills Development by University Students. *Review of European Studies*, 10(3), 58-71. <http://dx.doi.org/10.5539/res.v10n3p58>

- Azmi, I., Hashim, R., & Yusoff, Y. (2018). The Employability Skills of Malaysian University Students. *International Journal of Modern Trends in Social Sciences*, 1(3).Balangan, J., Elizabeth, D., Marjury, T., & Joanna, A. (2021). A Tracer Study on The Employability Status of Bachelor of Science in Environmental Science (BSES). Graduates From 2014 to 2018 of Benguet State University.
- Balcar, J. (2016). Is It Better to Invest in Hard or Soft Skills? *Economic and Labour Relations Review*, 27(4), 453-470. <http://dx.doi.org/10.1177/1035304616674613>
- Balcar, J., Simek, M., & Filipova, L. (2018). Soft Skills of Czech Graduates. *Review of Economic Perspectives*, 18(1), 45-60. <http://dx.doi.org/10.2478/revecp-2018-0003>
- Behle, H. (2020). Students' and Graduates' Employability. A Framework to Classify & Measure Employability Gain. *Policy Reviews in Higher Education*, 4(1), 105-130. <https://doi.org/10.1080/2332269.2020.172662>
- Benesová, A. & Tupa, J. (2017). Requirements for education and qualification of people in Industry 4.0. *Procedia Manufacturing*, 11, pp. 2195-2202.
- Borghans, L., Weel, B, T., & Weinberg, B, A. (2014). People Skills and The Labor-Market Outcomes of Underrepresented Groups. *ILR Review*, 67(2). <https://doi.org/10.1177%2F001979391406700202>
- Charlton, E. (2019). These Are the 10 Most In-Demand Skills, According To LinkedIn. *World Economic Forum*. <https://www.weforum.org/agenda/2019/01/most-in-demand-skills-as-per-linkedin/>
- Chaka, C. (2020). Skills, competencies and literacies attributed to 4IR/Industry 4.0: Scoping review. *IFLA Journal*, 46(4), 369–399. <https://doi.org/10.1177/0340035219896376>
- Ciappei, C., & Cinque, M. (2014). Soft Skills per Il Governo Dell'agire. *FrancoAngeli* <http://metodologieanimazione.pbworks.com/w/file/fetch/103970047/MetodologieDidatticheAttive.pdf>
- Cimatti, B. (2016). Definition, Development, Assessment of Soft Skills and Their Role for The Quality of Organizations and Enterprises. *International Journal for Quality Research*, 10(1), 97-130. <http://dx.doi.org/10.18421/IJQR10.01-05>
- Cinque, M. (2015). Comparative analysis on the state of the art of Soft Skill identification and training in Europe and some Third Countries. Speech at “Soft Skills and their role in employability – New perspectives in teaching, assessment and certification”, workshop in Bertinoro, FC, Italy.
- Clarke, M. (2017). Rethinking Graduate Employability: The Role of Capital, Individual Attributes and Context. *Studies in Higher Education*, 43(11), 1923-1937. <https://doi.org/10.1080/03075079.2017.1294152>
- Coetzee, M., Schreuder, D., & Tladinyane, R, T. (2014). Employees' Work Engagement And Job Commitment: The Moderating Role of Career Anchors. *SA Journal of Human Resources Management*, 12(1), 1-12. <http://dx.doi.org/10.4102/sajhrm.v12i1.572>
- Deloitte Access Economics. (2017). Soft Skills for Business Success. <https://www2.deloitte.com/content/dam/Deloitte/au/Documents/Economics/deloitte-au-economics-deakin-soft-skills-business-success-170517.pdf>
- Depret, N. (2019, January 14). 5 Points À Retenir De L'étude Monster Sur L'importance Des Soft-Skills. *Monster*. <https://www.monster.fr/conseil-carriere/article/5-points-a-retenir-sur-importance-soft-skills>
- Fogleman, D. (2019, May 17). Why We Should Start Calling Soft Skills “Employability Skills”. *Training Industry*. <https://trainingindustry.com/articles/leadership/why-we-should-start-calling-soft-skills-employability-skills/>
- Forsyth, P. (2019). *Successful Time Management: How to be Organized, Productive and Get Things Done* (5thed). Kogan Page. USA.

- Gerhardt, T. (2019). An Analysis of the Impact of a Leadership Intervention on an Undergraduate Work-Based Learning Project for Human Resource Management Students. *Journal of Work-Applied Management*, 11(1).
- LinkedIn Global Talent Trends. (2019). https://business.linkedin.com/content/dam/me/business/en-us/talent-solutions/resources/pdfs/global_talent_trends_2019_emea.pdf
- Gruzdev, M. V., Kuznetsova, I. V., Tarkhanova, I. Y., & Kazakova, E. I. (2018). University Graduates' Soft Skills: The Employers' Opinion. *European Journal of Contemporary Education*, 7(4), 690-698. <https://eric.ed.gov/?id=EJ1200952>
- Hamid, M. S. A., Islam, R., & Manaf, N. H. A. (2014). Employability skills development approaches: An application of the analytic network process. *Asian Academy of Management Journal*, 19(1), 93-111.
- Hlavackova, P., Lenoch, J., & Brezina, D. (2016). Analysis of the Graduate Employability At The Labour Market. ICEEPSY 2016 International Conference on Education and Educational Conference. <http://dx.doi.org/10.15405/epsbs.2016.11.21>
- Hurrell, S. A. (2016). Rethinking the Soft Skills Deficit Blame Game: Employers, Skills Withdrawal and the Reporting of Soft Skills Gaps. *Human Relations*, 69(3), 605-628. <http://dx.doi.org/10.1177/0018726715591636>
- Jeswani, S. (2017). Assessment of Employability Skills Among Fresh Engineering Graduates: A Structural Equation Modeling Approach. *The IUP Journal of Soft Skills*, 10(2), 7-43. https://papers.ssrn.com/sol3/papers.cfm?abstract_id=2914826
- Johnson, K. (2015). Non-Technical Skills for IT Professionals in the Landscape of Social Media. *American Journal of Industrial and Business Management*, 4(3), 102-122. <http://dx.doi.org/10.11634/216796061504668>
- Kashyap, S. (2019). Importance of Time Management in The Workplace. ProofHub. <https://www.proofhub.com/articles/importance-of-time-management-in-the-workplace>
- Kaushik, P., & Bansal, A. K. (2015). Enhancement in Soft Skills through Students Training Intervention. *International Journal of Advanced Information Science and Technology (IJAIST)*, 4(6), 150-157. <http://dx.doi.org/10.15693/ijaist/2015.v4i6.150-157>
- Kelly, P. T. (2017). Integrating Leadership Topics into An Accounting Ethics Course –Preparing Students for a Challenging Profession. *Advances in Accounting Education: Teaching and Curriculum Innovations*, 20, 141-180. <https://doi.org/10.1108/S1085-462220170000020007>
- Khanna, V. (2015). Soft Skills: A Key To Professional Excellence. *International Journal of Research in Engineering, Social Sciences*, 5(1), 32-40. http://indusedu.org/pdfs/IJRESS/IJRESS_728_43155.pdf
- Kirsty, D., Gregory, L., & Monte, W. (2016). A Content Analysis of Accounting Job Advertisements: Skill Requirements for Graduates. *E-Journal of Business Education and Scholarship of Teaching*, 10(1), 58-72. <https://eric.ed.gov/?id=EJ1167332>
- Klaus, P., Rohman, J. M., & Hamaker, M. T. L. (2007). *The Hard Truth About Soft Skills: Workplace Lessons Smart People Wish They'd Learned Sooner*. HarperCollins.E-Books. http://www.r-5.org/files/books/ethology/corporate/behaviour/Peggy_Klaus_The_Hard_Truth_About_Soft_Skills-EN.pdf
- Kornelakis, A., & Petrakaki, D. (2020). Embedding Employability Skills in UK Higher Education: Between Digitalization and Marketization. *Industry and Higher Education*, 34(3), 290-297. <http://dx.doi.org/10.1177/0950422220902978>
- Kruger, K. (2015, March 16). US Universities Should Follow UK in Promoting Students' 'Soft Skills'. *The World University Rankings*. <https://www.timeshighereducation.com/comment/opinion/us-universities-should-follow-uk-in-promoting-students-soft-skills/2019081.article>
- Labzina, P., Dobrova, V., Menshenina, S., & Ageenko, N. (2019). Soft Skills Enhancement Through

- Interdisciplinary Students Engagement. Proceedings of the International Conference Communicative Strategies of Information Society (CSIS 2018). <http://dx.doi.org/10.2991/csis-18.2019.69>
- Lavender, J. (2019). Soft Skills for Hard Jobs. *Journal of Continuing Education Topics and Issues*, 21(2). <https://www.thefreelibrary.com/Soft+Skills+for+Hard+Jobs.-a0592138127>
- Li, H., & Sun, Z. (2019). Study on The Definition of College Students' Employability. *ITM Web of Conferences*, 25(3). <http://dx.doi.org/10.1051/itmconf/20192504001>
- Li. S., Ibrahim, F., & Mustapha, S. (2019). Factors Contributing to Organizational Climate: Evidence from Small Medium Enterprises in China. *Infrastructure University Kuala Lumpur Research Journal*, 7(2).
- Low, M., Botes, V., & Allen, J, M. (2016). Accounting Employers' Expectations – The Ideal Accounting Graduates. *E-Journal of Business Education and Scholarship of Teaching*, 10, 36-57. <https://www.semanticscholar.org/paper/Accounting-Employers%27-Expectations--The-Ideal-Low-Botes/b6f0f637e053ed937ecd316e0faefe63e527ee7c>
- Meclachlan. (2019). The Importance of Soft Skills for Employability and Career Development. <https://www.coursehero.com/file/79936550/The-Importance-of-Soft-Skills-for-Employability-and-Career-Developmentpdf/>
- Majid, M, Z, A., Hussin, M., Norman, M, H., & Kasavan, S. (2020). The Employability Skills Among Students of Public Higher Education Institution in Malaysia. *Malaysian Journal of Society and Space*, 16(1), 36-45. <https://doi.org/10.17576/geo-2020-1601-04>
- Majid, S., Eapen, C, M., & Oo, K, T. (2019). The Importance of Soft Skills for Employability and Career Development: Students and Employers' Perspectives. *The IUP Journal of Soft Skills*, 13(7). <https://www.semanticscholar.org/paper/The-Importance-of-Soft-Skills-for-Employability-and-Majid-Eapen/b227efe45c29d0cce176e11ad9df0f39413623a1>
- Matteson, M, L., Anderson, L., & Boyden, C. (2016). "Soft Skills": A Phrase in Search of Meaning. *Johns Hopkins University Press*, 16(1), 71-88. <https://doi.org/10.1353/pla.2016.0009>
- Mavrikios, D., Georgoulas, K. & Chryssolouris, G. (2018). The teaching factory paradigm: Developments and outlook. *Procedia Manufacturing*, 23, pp. 1-6
- Naim, M. (2017). Soft Skill Development: Relevance of Neuro-Linguistic Programming (NLP). 17, 160-176. <http://www.languageinindia.com/feb2017/maryasoftskills.pdf>
- Natalia, C., Maria, S., Vladislav, S., & Paquet, P. (2015). Problems of Educational Processes Development and Labor Market Needs Analysis in Russia. *International Conference On Research Paradigms Transformation in Social Sciences 2014*, 166, 309-316. <http://dx.doi.org/10.1016/j.sbspro.2014.12.529>
- Nathan, S, K., & Rajamanoharan, S. (2016). Enhancement of Skills Through E-Learning: Prospects and Problems. *The Online Journal of Distance Education and E-Learning*, 4(3), 24-32. <https://tojdell.net/journals/tojdel/articles/v04i03/v04i03-02.pdf>
- Nazron, M, A., Lim, B., & Nga, J, L, H. (2017). Soft Skills Attributes and Graduate Employability: A Case in Universiti Malaysia Sabah. *Malaysian Journal of Business and Economics*, 4(2). <https://jurcon.ums.edu.my/ojums/index.php/mjbe/article/view/1080>
- Nirmala, K., & Kumar, S. (2018). The Impact of Basic, Higher-Order Thinking and Affective Skills on Graduate Employability. *The IUP Journal of Soft Skills*, 3(1), 7-28. <https://www.semanticscholar.org/paper/The-Impact-of-Basic%2C-Higher-Order-Thinking-and-on-Nirmala-Kumar/8491461b33061cb527f9f1fdd0bd03654b4eeea0>
- Nusrat, M., & Naz, K. (2018). Soft Skills for Sustainable Employment: Does It Really Matter? *International Journal of Management and Economics Invention*, 4(7), 1835-1837. <http://dx.doi.org/10.31142/ijmei/v4i7.03>
- Nusrat, M., & Sultana, N. (2019). Soft Skills for Sustainable Employment of Business Graduates of Bangladesh. *Higher Education, Skills, and Work-Based Learning*,

- 9(3). <https://www.emerald.com/insight/content/doi/10.1108/HESWBL-01-2018-0002/full/html>
- Okolie, U. C., & Asfa, M. Y. (2017). Human development and TVET dimensions. Technical education and vocational training in developing nations. Hershey, PA: IGI-Global International Publishers.
- Ornellas, A., Falkner, K., & Stalbrandt, E. E. (2019). Enhancing Graduates' Employability Skills Through Authentic Learning Approaches. *Higher Education, Skills, and Work- Based Learning*, 9, 107-120. <https://doi.org/10.1108/HESWBL-04-2018-0049>
- Osmani, M., Weerakkody, V., Hindi, N. M., Al-Esmail, R., Eldabi, T., Kapoor, K., & Irani, Z. Identifying The Trends and Impact of Graduate Attributes Employability: A Literature Review. *Tertiary Education and Management*, 21(4), 367-379. <https://doi.org/10.1080/13583883.2015.1114139>
- Oussii, A. A., & Klibi, M. F. (2017). Accounting Students' Perceptions of Important Business Communication Skills for Career Success: An Exploratory Study in The Tunisian Context. *Journal of Financial Reporting and Accounting*, 15(2). <https://www.emerald.com/insight/content/doi/10.1108/JFRA-10-2015-0092/full/html>
- Pachauri, D., & Yadav, A. (2014). Importance of Soft Skills in Teacher Education Programme *International Journal of Educational Research and Technology*, 5(1), 22-25. <http://educatorsresource.in/wp-content/uploads/2015/10/Importance-of-Soft-Skills-in-Teacher-Education-Programme.pdf>
- Patacsil, F. F., & Tablatin, C. L. S. (2017). Exploring The Importance of Soft and Hard Skills As Perceived by IT Internship Students and Industry Gap Analysis. *Journal of Technology and Science Education*, 7(3), 347-368. <http://dx.doi.org/10.3926/jotse.271>
- Penratanahiran, R., & Thongkham, K. (2021). A Survey of Soft Skills Needed in the 21st Century Workplace. *Rajabhat Rambhai Barni Research Journal*, 15(1), 59-69. <https://so05.tci-thaijo.org/index.php/RRBR/article/view/250889>
- Phago, M., & Thwala, L. (2015). Baseline Study on Students' Perceptions and Attitudes Towards The HWSETA Postgraduate Research Bursary Programme – Full Paper. <https://www.hwseta.org.za/download/baseline-study-on-students-perceptions-and-attitudes-towards-the-hwseta-postgraduate-research-bursary-programme-full-paper/#>
- Poblete-Ruiz, M. (2015). How To Teach and Develop Soft Skills. Evolution of Generic Skills (Soft skills) Following the Declaration of Bologna 1999. Speech at “Soft Skills and Their Role in Employability –New Perspectives in Teaching, Assessment and Certification”. Workshop in Bertinoro, FC, Italy.
- Rahmat, N., Ayub, A. R., & Buntat, Y. (2017). Employability skills constructs as job performance predictors for Malaysian polytechnic graduates: A qualitative study. *Geografia-Malaysian Journal of Society and Space*, 12(3), 154 - 167.
- Ramalu, J., Bakar, N., & Nijar, N. (2013). Factors That Determine Students' Preferences in Selecting Higher Learning Institution. *Infrastructure University Kuala Lumpur Research Journal*, 1 (1).
- Ramlan, R., & Ngah, S. (2015). Student Perception on the Importance of Soft Skills for Education and Employment. *PEOPLE: International Journal of Social Sciences*, 1(1), 696-708.
- Rao, M. S. (2018). Soft Skills: Toward A Sanctimonious Discipline. *On The Horizon*, 26(3), 215-224. <https://doi.org/10.1108/OTH-06-2017-0034>
- Robles, M. M. (2012). Executive Perceptions of the Top 10 Soft Skills Needed in Today's Workplace. *Business and Professional Communication Quarterly*, 74(4), 453- 465. <https://doi.org/10.1177%2F1080569912460400>
- Romgens, I., Scoupe, R., & Beusaert, S. (2019). Unraveling The Concept of Employability, Bringing Together Research on Employability in Higher Education and The Workplace. *Studies in Higher Education*, 45(12), 2588-2603. <https://doi.org/10.1080/03075079.2019.1623770>

- Roos, S., Lennox, A., & Botha-Ravuse, C. (2016). Student's Soft Skill Acquisition in An Outdoor Adventure Education Event Over Two Years of Participation. *International Journal of Social Sciences and Humanity Studies*, 8(2), 196-208
https://www.researchgate.net/publication/318969580_Student%27s_Soft_Skill_Acquisition_in_an_outdoor_adventure_education_event_over_two_years_of_participation
- Rothwell, A., & Rothwell, F. (2017). Graduate Employability: A Critical Oversight. *Graduate Employability in Context* (pp. 41-63). http://dx.doi.org/10.1057/978-1-137-57168-7_2
- Salleh, K. M., Subhi, N. I., Sulaiman, N., & Latif, A. A. A. (2016). Generic Skills of Technical Undergraduates and Industrial Employers Perceptions in Malaysia. *International Journal of Applied Business and Economic Research*, 14(14), 907-919.
https://www.researchgate.net/publication/316936108_Generic_skills_of_technical_undergraduates_and_industrial_employers_perceptions_in_Malaysia
- Salleh, R., Yusof, M. A. M., & Memon, M. A. (2016). Attributes of Graduates Architects: An Industry Perspective. *The Social Sciences*, 11(5), 551-556.<http://dx.doi.org/10.36478/sscience.2016.551.556>
- Sanyal, S., & Hisam, M. W. (2018). The Impact of Teamwork on Work Performance of Employees: A Study of Faculty Members in Dhofar University. *Journal of Business And Management*, 20(3), 15-22. <http://dx.doi.org/10.9790/487X-2003011522>
- Schallock, B., Rybski, C., Jochem, R. & Kohl, H. (2018). Learning factory for Industry 4.0 to provide future skills beyond technical training. *Procedia Manufacturing*, 23, pp. 27-32.
- Shivoro, R., Shalyefu, R. K., & Kadhila, N. (2017). Perspectives on Graduate Employability Attributes for Management Sciences Graduates. *South Africa Journal of Higher Education*, 32(1), 216-232. <http://dx.doi.org/10.20853/32-1-1578>
- Singh, A., & Jaykumar, P. (2019). On The Road to Consensus: Key Soft Skills Required For Youth Employment in The Service Sector. *Worldwide Hospitality and Tourism Themes*, 11(1), 10-24. <http://dx.doi.org/10.1108/WHATT-10-2018-0066>
- Singh, R., Chawla, G., Agarwal, S., & Desai, A. (2017). Employability and innovation: Development of a scale. *International Journal of Innovation Science*, 9(1), 20-37.
- Sousa, M. J., & Rocha, A. (2017). Game-Based Learning Contexts for Soft Skills Development. In: Rocha, A., Correia, A., Adeli, H., Reis, L., Costanzo, S (eds.) *Recent Advances in Information Systems and Technologies. WorldCIST 2017. Advances in Intelligent Systems and Computing*, 570. https://link.springer.com/chapter/10.1007%2F978-3-319-56538-5_92
- Steward, C., Wall, A., & Marciniak, S. (2016). Mixed Signals: Do College Graduates Have The Soft Skills That Employers Want? *Competition Forum*, 14, 276-281.
https://www.researchgate.net/publication/316066488_Mixed_Signals_Do_College_Graduates_Have_the_Soft_Skills_That_Employers_Want
- Sung, J., NG, C.M., Loke, F., & Ramos, C. R. (2013). The Nature of Employability Skills: Empirical Evidence from Singapore. *International Journal of Training and Development*, 17(3), 176-193.
- Tripathy, M. (2018). Building Quality Teamwork to Achieve Excellence in Business Organizations. *International Research Journal of Management, IT and Social Sciences*, 5(3), 1-7.
<http://dx.doi.org/10.21744/irjmis.v5i3.662>
- Tripathy, M. (2020). Significance of Soft Skills in Career Development. *Career Development and Job Satisfaction*. <http://dx.doi.org/10.5772/intechopen.89935>
- Truong, T. T. H., Laura, R. S., & Shaw, K. (2018). The Integral Role Played by Soft Skills in Advancing Business Management Success. *International Journal of Management and Economics*, 4(1), 1552-1565. <http://dx.doi.org/10.18535/ijmei/v4i1.03>
- Uzun, T., & Ayik, A. (2017). Relationship Between Communication Competence and Conflict Management Styles of School Principals. *Eurasian Journal of Educational Research*, 17(68), 169-188. <http://dx.doi.org/10.14689/ejer.2017.68.9>

- Valdez, C. (2015). Assessment is Taking Discretion Away from Employer's Use of Criminal Background Checks. *Cleveland State Law Review*, 63(2), 541-566.
- Vanitha, P., & Jaganathan, A. T. (2019). A Study on Enhancing Employability Skills of Graduates in India. *International Journal of Trend in Scientific Research and Development*, 2(2), 947-951. <http://www.ipindexing.com/article/13923>
- Vyas, A. (2019). A Study of Soft Skills to Be Instilled Within Management Students. *International Journal of Research and Analytical Reviews*, 6(1), 1088-1092. <https://ijrar.org/papers/IJRAR19J1452.pdf>
- Wharton, C. Y., Goodwin, L. J., & Cameron, A. J. (2014). Living Up to Our Students' Expectations – Using Student Voice to Influence the Way Academics Think About Their Undergraduates Learning and Their Own Teaching. *International Journal of Higher Education*, 3(4). <https://doi.org/10.5430/ijhe.v3n4p72>
- Williams, S., Dodd, L. J., Steele, C., & Randall, R. (2015). A Systematic Review of Current Understandings of Employability. *Journal of Education and Work*, 29(8), 877-901. <https://doi.org/10.1080/13639080.2015.1102210>
- Zuo, J., Zhao, X., Nguyen, Q., Ma, T., Gao, S. (2018). Soft Skills of Construction Project Management Professionals and Project Success Factors: A Structural Equation Model. *Engineering, Construction and Architectural Management*, 25(3). <https://doi.org/10.1108/ecam-01-2016-0016>